

## Lever-Operated Oil Gun

### Description

This model oil gun is designed with Buna-N (Nitrile) seals to dispense oil.

The gun delivers slightly more than 1 fluid ounce (30.8 cm<sup>3</sup>) of product in seven cycles [2-strokes per cycle - one upward and one downward].

### Operation

#### Fill the Gun

1. Unscrew Cylinder (13) from Head Assembly (3). See **Figure 2**.
2. Pull Rod and Handle Assembly (10) fully to the back of the Cylinder and allow it to latch.

3. Fill the Cylinder with fluid.
4. Screw the Head Assembly onto the Cylinder.
  - Tighten the Head Assembly securely.
5. Release the Rod and Handle Assembly from Latch (11).
6. Push the Rod and Handle Assembly into the Cylinder until it seats on the Latch.

### Specifications

Reservoir Capacity		Delivery/Cycle		Maximum Operating Pressure	
Fluid Ounces	Liter	Fluid Ounce	cm <sup>3</sup>	psi	Bars
26	0.77	0.15	4.4	1800	124

**Table 1** *Lever-Operated Oil Gun Specifications*

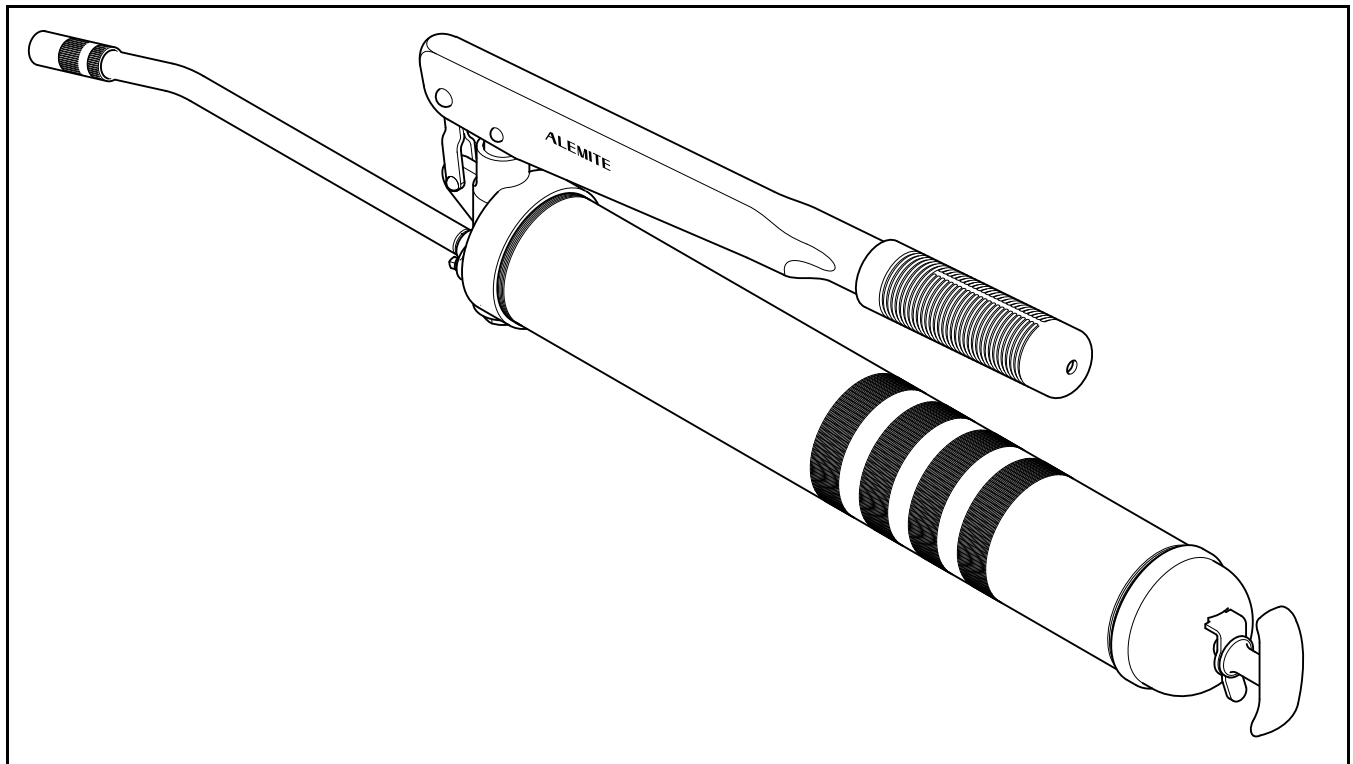

**Figure 1** *Lever-Operated Oil Gun Model 4035*

Alemite LLC  
 167 Roweland Drive, Johnson City, Tennessee 37601  
[www.alemite.com](http://www.alemite.com)

Copyright © 2009 by Alemite LLC

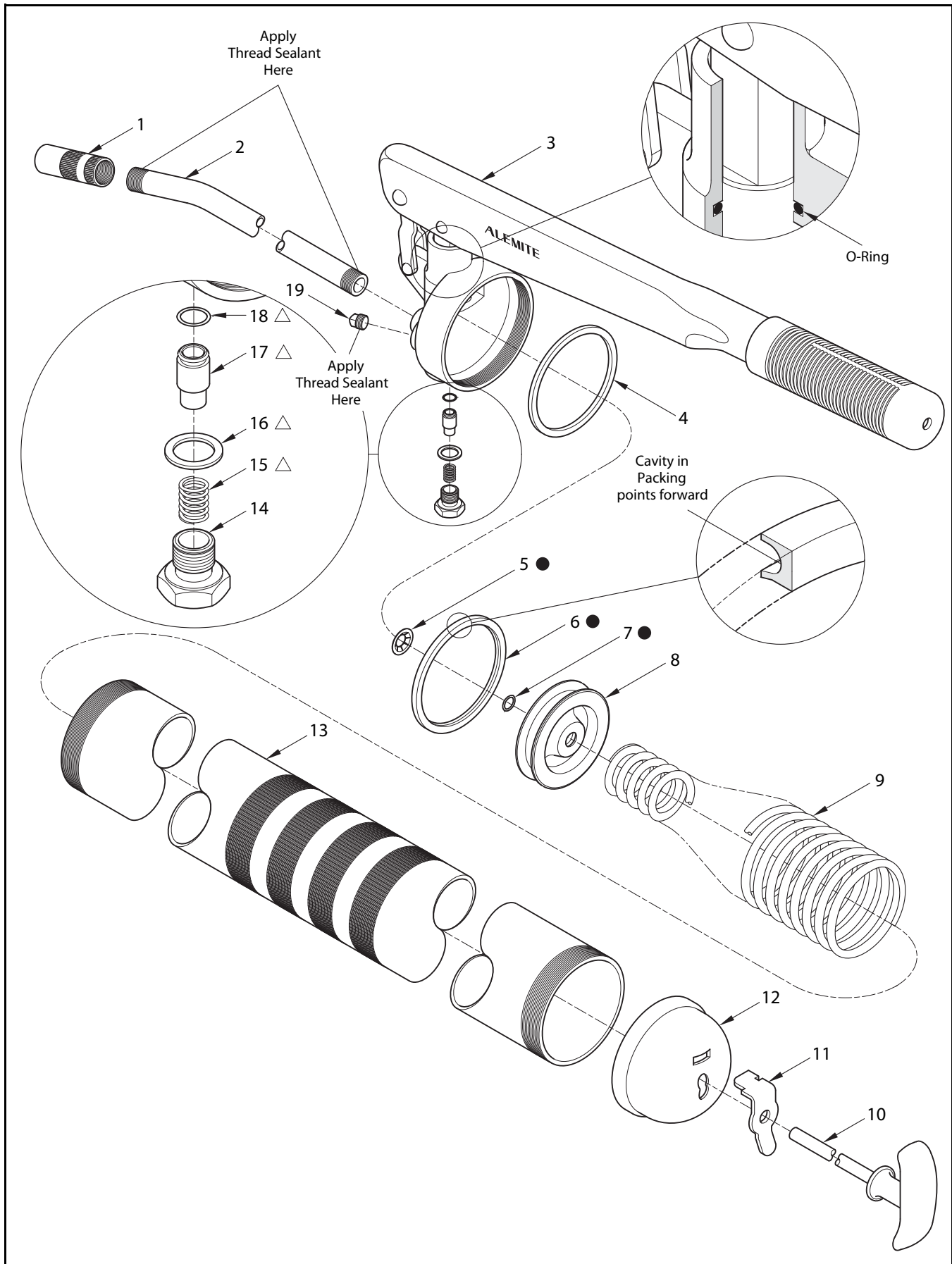

Figure 2 Lever-Operated Oil Gun - Exploded View

Item No.	Part No.	Description	Qty	Notes
1	308730-A	Coupler	1	
2	53986	Extension	1	
3		Head Assembly	1	
4	336523	Gasket (Nitrile)	1	
5		Pushnut	1	●
6		Packing, Block-V (Nitrile)	1	●
7		O-Ring, 5/16" ID x 7/16" OD	1	●
8		Follower (Aluminum)	1	
9		Spring	1	
10		Rod and Handle Assembly	1	
11		Latch	1	
12		Cap	1	
13		Cylinder	1	
14		Plug, 9/16" -20	1	
15		Spring	1	△
16	303247	Gasket (Aluminum)	1	△
17		Plunger	1	△
18	X171000-5	O-Ring, 1/4 " ID x 3/8 " OD	1	△
19	1480	Plug, Pipe	1	

**Legend:**  
Part numbers left blank are not available separately  
●△ designates a repair kit item

### Repair Kits

Part No.	Kit Symbol	Description
<b>393680</b>	●	Kit, Repair, Follower
<b>393681</b>	△	Kit, Repair, Plunger

## Bleed the Gun

1. Point the gun with the Head Assembly upward.
2. Cushion Coupler (1) with a clean rag.

3. Slowly operate the lever and watch for fluid at the Coupler.

Once fluid appears:

4. Remove the rag from the Coupler.

---



---

### WARNING

**Operate the lever of the gun slowly. Excessive speed can result in a pressurized discharge of fluid that can result in injury to personnel.**

---



---

## Troubleshooting Chart

Gun Indications	Possible Problems	Solution
Gun does not pump	Air within Head Assembly (3)	Bleed the gun
Gun lacks pressure	1. Worn or damaged check valve 2. Worn piston and/or bore in Head Assembly (3)	1. Use Plunger Repair Kit 393681 2. Replace oil gun
<b>Leaks</b>		
Oil leakage visible at Cap (12)	Worn or damaged Block-V Packing (6) or damaged O-Ring (7)	Use Follower Repair Kit 393680
Oil leakage visible between Cylinder (13) and Head Assembly (3)	1. Initial tightening of Cylinder (12) into Head Assembly (3) not sufficient 2. Worn or damaged Gasket (4)	1. Tighten Cylinder (12) into Head Assembly (3) 2. Replace Gasket (4)
Oil leakage visible at Plug (14)	1. Initial tightening of Plug (14) into Head Assembly (3) not sufficient 2. Worn or damaged Gasket (16)	1. Tighten Plug (14) into Head Assembly (3) 2. Replace Gasket (16)
Oil leakage visible at Coupler (1)	Worn or damaged O-Ring (18)	Replace O-Ring (18)
Oil leakage visible at Extension (2)	1. Initial tightening of Extension (2) into Head Assembly (3) and/or Coupler (1) not sufficient 2. Thread sealant missing or inadequate	1. Tighten Extension (2) into Head Assembly (3) and Coupler (1) into the Extension 2. Apply thread sealant* to each end of Extension (2)
Oil leakage visible at top of Head Assembly (3)	Worn or damaged O-Ring in Head Assembly (3). See <b>Figure 2</b> .	Replace oil gun
* Do not apply thread sealant to the first two (2) threads. Contamination can occur.		

**Changes Since Last Printing**  
Updated repair parts and kits